

RECOMMENDATIONS FOR THERMALLY CONDUCTIVE WASHERS

Apex thermal washers are also available from Power Devices. "Thermstrate" is the material trade name for these washers unless the model specification states otherwise. These washers are pre-coated aluminum stampings which provide better thermal conductivity than thermal grease, easier use and freedom from application variables. Electrical conductivity of these washers makes sleeving of at least two opposing pins a requirement to achieve correct alignment. A small number of Apex washers are noted to be electrically insulating or made of Kapton. These are made of "Isostrate" material, type MT Kapton with over twice the thermal conductivity of type HN Kapton. Thermal performance is similar to a mica washer with thermal grease. Both types are 3 mils thick and NON-COMPRESSIBLE.

HEATSINK THRU-HOLES

Custom heatsink manufacture or mounting of the Apex power amplifier to a bulkhead for heatsinking, requires the use of individual heatsink thru-holes for the external connection pins. For the 8-pin TO-3 package the main path for heat flow occurs inside the circumference of 8 pins. (Refer to Figure 1)

Therefore, a single large hole, (to allow the 8 pins to pass through), will remove the critical heatsink material from where it is most needed. Instead, 8 separate holes must be drilled. Refer to Table 1 for recommended drill sizes for heatsink thru-holes for Apex power amplifier packages.

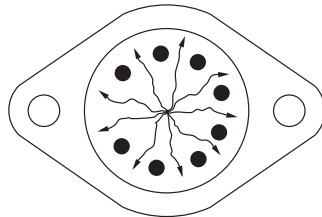

Fig. 1: Main heat flow path, 8-pin to TO-3 package.

PIN DIAMETER	RECOMMENDED DRILL SIZE	HOLE DIAMETER INCHES	HOLE DIAMETER mm
.025"	#50	.070±.002	1.781±.051
.040"	#46	.081±.002	2.057±.051
.060"	#37	.104±.002	2.642±.051

Table 1: Heatsink thru-hole sizes.

TEFLON TUBING

Anodized heatsinks can be easily nicked or scratched, exposing bare aluminum, which is an excellent electrical conductor. When mounting the Apex power amplifier using a socket, it is recommended to sleeve, with Teflon tubing, a minimum of two opposite pins. This centers the external connection pins in the heatsink thru-holes and prevents electrical shorts when tightening the power amplifier down on a heatsink. When soldering directly to external connection pins it is recommended to sleeve, with Teflon tubing, all pins. Table 2 lists the recommended Teflon tubing and some suggested manufacturers (for manufacturers' phone numbers, see "Vendors for Power Op Amp Accessories").

TUBING DIMENSIONS						
PIN DIAMETER	Nominal I.D.		Nominal O.D.		MFG.	PART NO.
	Inches	mm	Inches	mm		
.025"	.028	.711	.052	1.321	★	TSI-S22
					★★	TFT-250-22
.040"	.042	1.067	.074	1.88	★	TSI-S18
					★★	TFT-250-18
.060"	.056	1.676	.098	2.489	★	TSI-S14
					★★	TFT-250-14

Table 2: Teflon tubing. ★ SPC Technology
★★ Alpha Wire Corp.

Teflon meets all known requirements but many other materials will work fine in some applications if three requirements are met. The tubing must fit the pin and the heatsink hole, it must be rated for the maximum voltage of the application and it must be rated for the temperature extremes of the application. Simply stripping the insulation from #14, #18 or #22 wire may be a viable tubing source.

HEATSINKS

A wide spectrum of applications can be satisfied with the heatsinks stocked as accessories for APEX power amplifiers. All are made of aluminum to provide high levels of conduction. HS01 clamps over the TO-3 case using virtually no additional space on a printed circuit board. Some are suitable for chassis or printed circuit mounting. Some are designed for chassis mounting only. The HS11 provides the most protection for prototyping or for production of high power products. All heatsinks are pre-drilled with hole patterns as shown. Conservative calculations are recommended for prototype work while performance graphs are included to enable optimization for production runs. Due to calculation complexity of thermal circuits and of power dissipation levels where reactive loads are driven, it is often helpful to utilize temperature measurements after the electrical design has been completed.

Heatsink ratings seen in the Apex Application Notes are thermal resistance from ambient fluid (usually air) to the mounting area in the center of the hole pattern. Do not forget to add the thermal resistance of the interface between the heatsink and the amplifier (see model specific Application Notes). These ratings are for the heatsink with unobstructed air flow with optimum mounting orientation (extrusions would be suspended in mid-air with fins running vertically) and dissipating enough power to raise the heatsink mounting surface 75°C above ambient. While this convention seems to be common among heatsink manufacturers, making it easy to compare offerings, it often leaves the designer of an amplifier circuit with considerable work to do.

Let us first consider the 75°C rise above ambient condition. Apex experience indicates this is a quite large number. Our research has found substantially different graphs for correcting thermal ratings for different temperature rises. A conservative approach is to increase thermal resistance 0.8%/°C for lower temperature rise applications. A heatsink rated at 1°C but required to limit temperature rise to only 60°C would be expected to perform at about 1.12°C/W.

HEATSINKS

The conditions of optimum orientation and unobstructed air flow are also elusive in many power amplifier applications. Orientation and PC boards or cabinets obstructing air flow sometimes reduce thermal performance; fans sometimes enhance it. Calculating the improvement of adding a fan is not a single step job. When a graph is provided for a heatsink, the air flow is given in velocity, but most fans are rated in cubic delivery, and this rating varies with pressure. The Heatsinks sheet of the Apex Power Design spreadsheet (Excel) will help with the cubic to velocity conversion. The degree of improvement in thermal performance achieved with forced air cooling varies with physical features of the heatsink. The following graph is a composite of known performance and can be used as an approximation of improvement possible with the addition of a fan when the specific heatsink does not have its own graph.

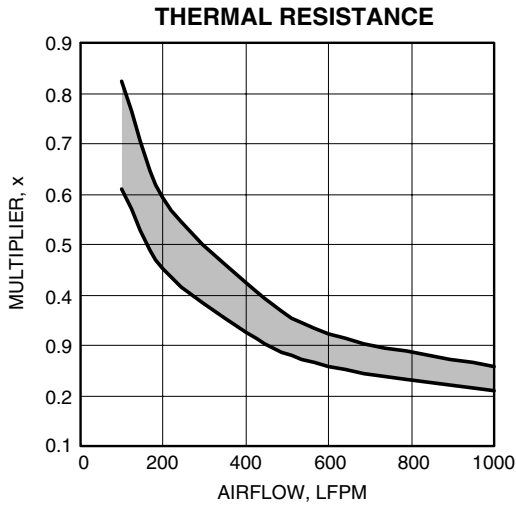

THERMAL INTERFACE

Both mounting surfaces of the heatsink and the amplifier are rough and non-flat to a degree where thermal performance will be compromised if a medium to fill voids is not included in between these surfaces. Silicone based thermal compound has a long track record of satisfactory performance when the fluid base and the filler have not been allowed to separate and are applied in a thin, even and complete layer. Apex thermal washers also have a proven track record showing advantages of much lower process variability than manually applied thermal grease. When using aluminum based washers, installation must insure the washer does not touch the pins of the amplifier. See the TEFLON TUBING paragraph above.

DO NOT USE COMPRESSIBLE THERMAL WASHERS. The Apex failure analysis team has seen many cases where compressible pads lead to cracked ceramic inside the amplifier when mounting screws are torqued down. Many Apex data sheets proclaim the product warranty is void if these products are used.

CAGE JACKS AND MATING SOCKETS

In addition to allowing amplifiers to be replaced without soldering (and potential PC board damage), cage jacks and mating sockets prevent solder joint stress when the amplifier/heatsink assembly is rigidly fastened to the PC board and is subjected to wide temperature variations. Cage jacks are inserted and soldered into PC boards for each individual pin of an amplifier. The MS06 mating socket is used in the same manner as cage jacks. Other mating sockets can be inserted into PC boards, but also have turret terminals for direct wiring.

HS01

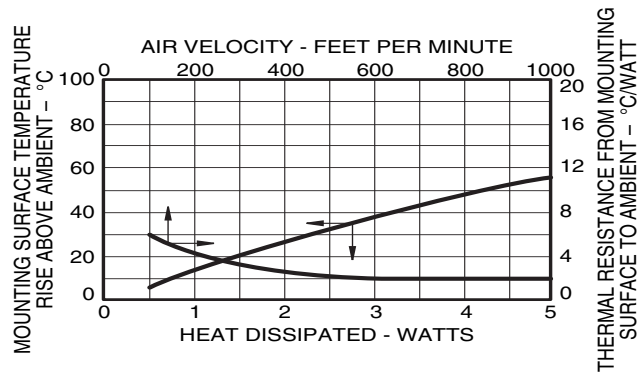

HS02

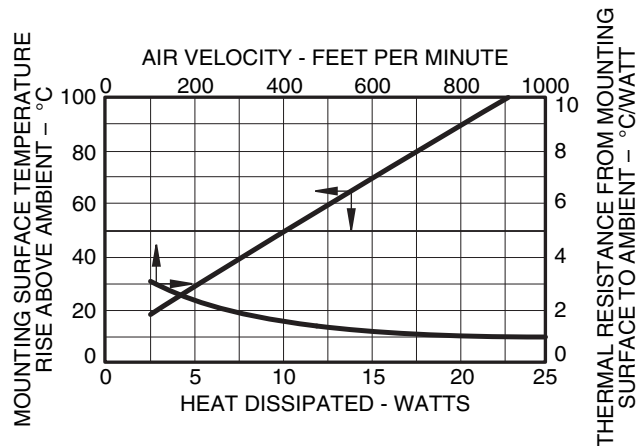

HS03

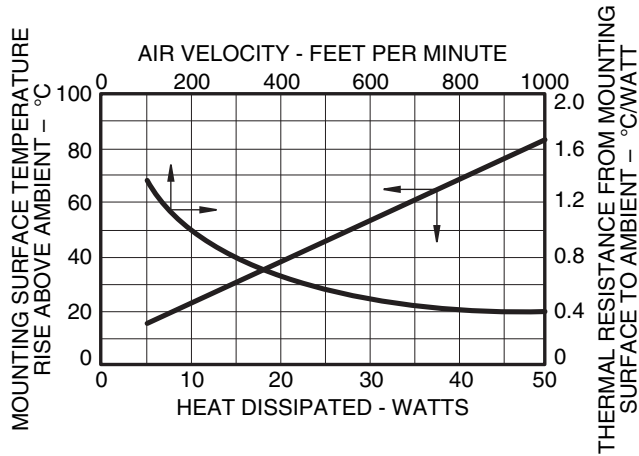

HS05

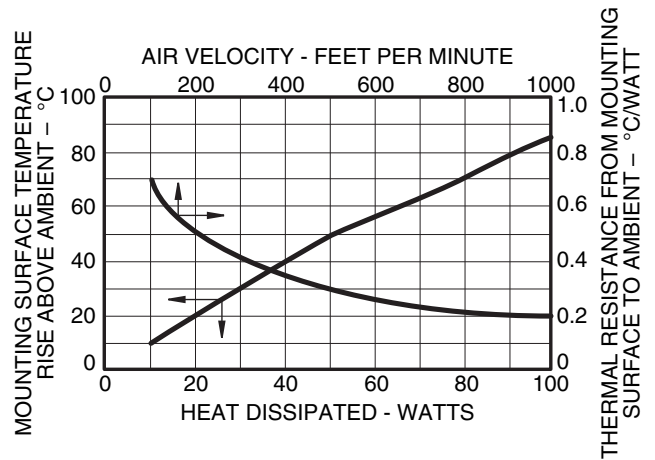

HS04

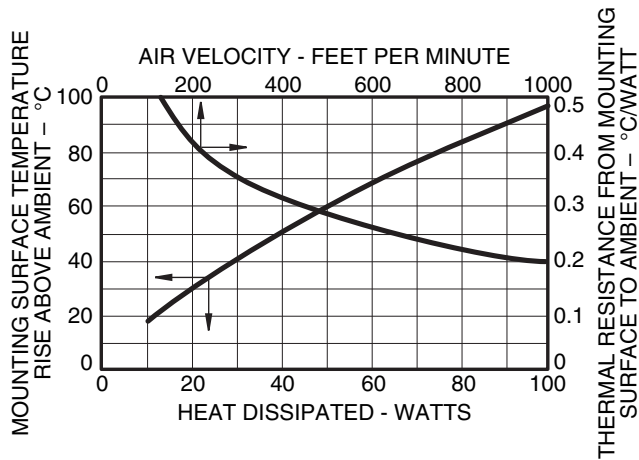

HS06

Thermal Resistance: $\approx .96^{\circ}\text{C/W}$

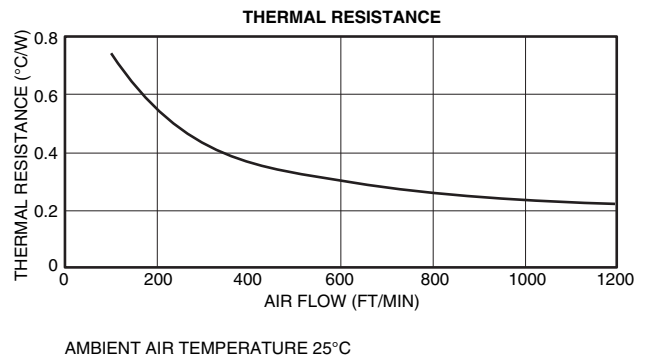

HS09

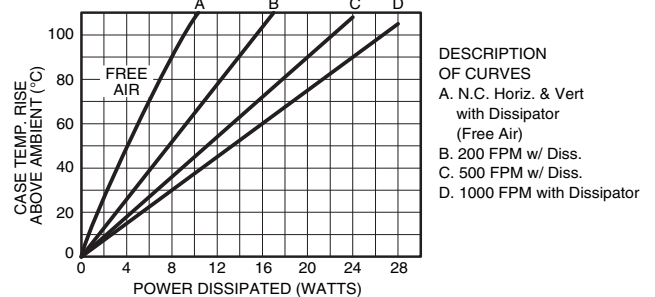

HS11

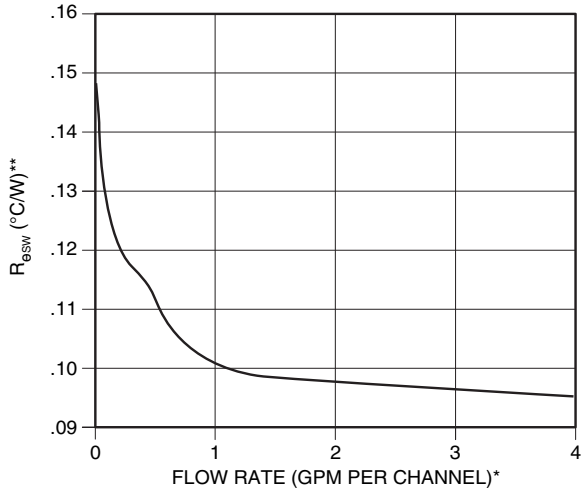

$R_{\theta_{sw}} = .675 \text{ }^{\circ}\text{C}/\text{W}$ (Free air vertical)

$R_{\theta_{sw}} = .102 \text{ }^{\circ}\text{C}/\text{W}$ (Water cooled @ 1 GPM per channel)

Additional mounting loss (with thermal grease):

PD12: .008 - .017 $^{\circ}\text{C}/\text{W}$

TO-3: .05 - .1 $^{\circ}\text{C}/\text{W}$

* BOTH CHANNELS FED IN PARALLEL USING CLEAN WATER

** $R_{\theta_{sw}}$ = THERMAL RESISTANCE FROM HEATSINK TO WATER

HS13

Thermal Resistance: 1.48 $^{\circ}\text{C}/\text{W}$

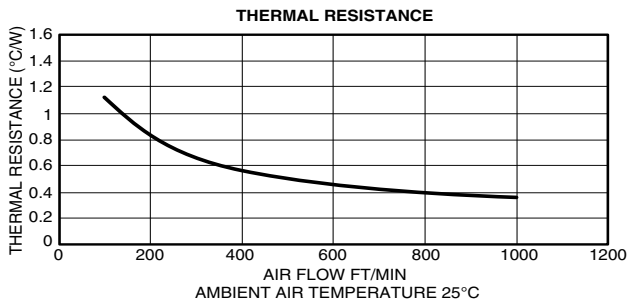

HS16

Thermal Resistance: 2 $^{\circ}\text{C}/\text{W}$

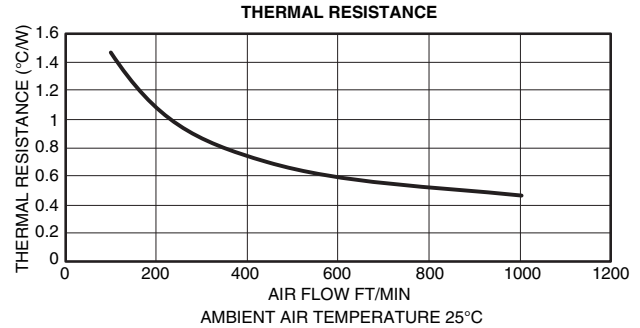

HS14

Thermal Resistance: 2 $^{\circ}\text{C}/\text{W}$

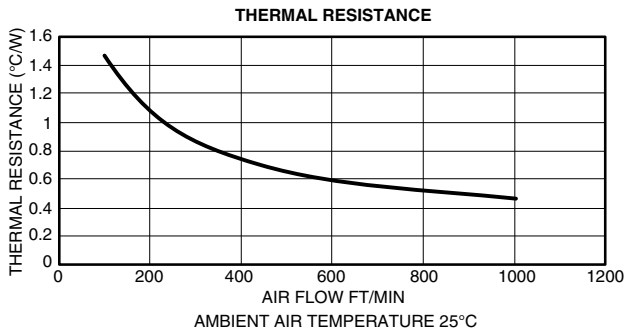

HS21

$R_{\theta SA} = 5.6^{\circ}\text{C/W}$

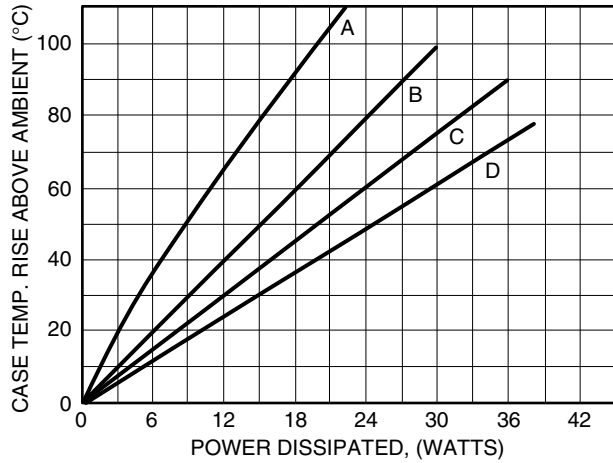

DESCRIPTION OF CURVES

- A. Free air
- B. 200FPM forced air
- C. 500FPM forced air
- D. 1000FPM forced air

HS31

Thermal Resistance: 1.48°C/W

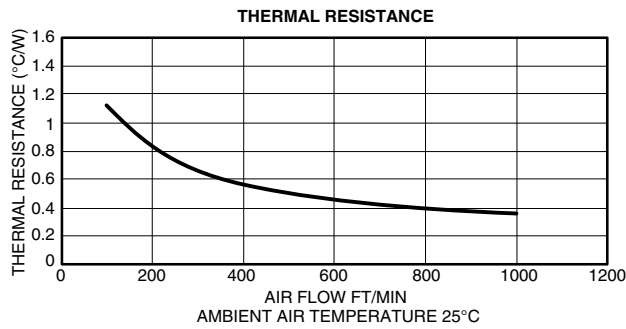

HARDWARE KIT

ACCESSORIES
INFORMATION

HK26/HARDWARE KIT FOR DX (SIP12) PACKAGE

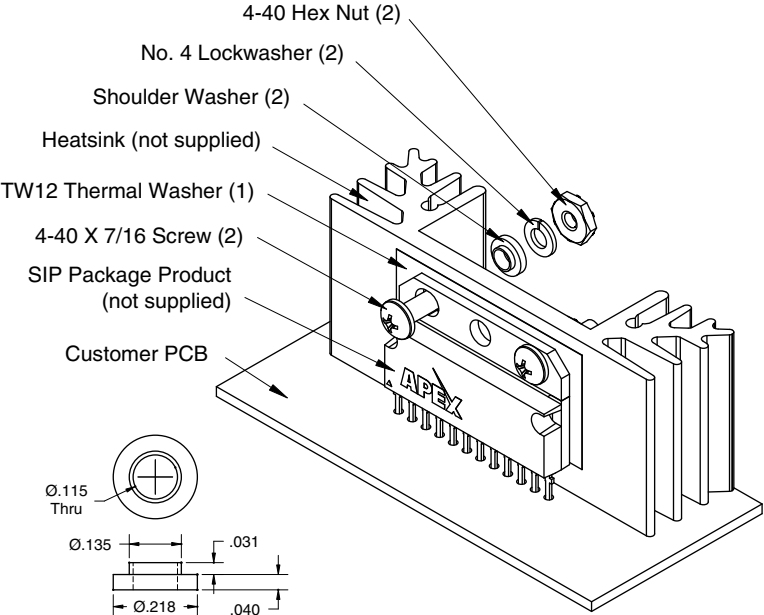

Shoulder Washer Dimensions

Keystone Part No. 3049
Nylon 6/6 per ASTM D4066

VENDORS FOR POWER AMPLIFIER ACCESSORIES

The following list answers the most common requests received on the APEX Applications Hotline. It is by no means a complete list of sources, but can save you valuable time locating requirements not found in the Apex data book.

CAGE JACKS

Mill-Max Manufacturing Corp.
516-922-6000 Fax 516-922-9253
<http://www.mill-max.com>

CHIP CAPACITORS

NOVACAP
800-227-2447 Fax 661-295-5928
<http://www.info@novacap.com>

CORES

Magnetics
800-245-3984 Fax 412-696-0333
<http://www.mag-inc.com>

Micrometals, Inc.

714-970-9400, 800-356-5977 Fax 714-970-0400
<http://www.micrometals.com>

FAST DIODES

Intersil Corp.
888-468-3774 Fax 321-724-7000
<http://www.intersil.com>

MicroSemi

800-713-4113 Fax 949-756-0308
<http://www.microsemi.com>

Philips Components

800-447-1500
<http://www.semiconductors.philips.com>

Semtech

805-498-2111 Fax 805-498-3804
<http://www.semtech.com>

Vishay

610-407-4800 Fax 610-640-9081
<http://www.vishay.com>

HEATSINKS

AAVID Thermalloy Technologies, Inc
603-224-9988 Fax 603-223-1790
<http://www.aavidthermalloy.com>

Wakefield Engineering

603-635-2800 Fax 603-635-1900
<http://www.wakefield.com>

International Electronic Research Corp.
818-842-7277 Fax 818-848-8872

HIGH VOLTAGE SUPPLIES

International Power
805-981-1188 Fax 805-981-1184
<http://www.internationalpower.com>

Power-One Inc.

805-987-8741 Fax 805-388-0476
<http://www.power-one.com>

UltraVolt, Inc. DC/DC Converters

800-876-7693 Fax 631-471-4696
<http://ultravolt.com>

Emco High Voltage

209-223-3626 Fax 209-223-2779
www.emcohighvoltage.com

HIGH WATTAGE SUPPLIES

DYNA Power Corp.
248-471-1800
<http://www.dynapower.com>

Elgar Electornics Corp.

800-733-5427 Fax 858-458-0267
<http://www.elgar.com>

LOW VALUE RESISTORS

Caddock Electronics, Inc.
951-788-1700 Fax 951-369-1151
<http://www.caddock.com>

ISOTEK

800-569-6467 Fax 508-676-0855
<http://www.isotekcorp.com>

Vishay Dale Electronics

402-564-3131 Fax 402-563-6418
<http://www.vishay.com>

Riedon, Inc.

626-284-9901 Fax 626-282-1704
<http://www.riedon.com>

Vishay

610-407-4800 Fax 610-640-9081
<http://www.vishay.com>

—Continued on following page

—Continued from previous page

RESISTANCE WIRE

MWS Wire Industries

818-991-8553 Fax 818-706-0911
<http://www.mswire.com>

TEFLON TUBING

Alpha Wire Corp.

800-522-5742 Fax 908-925-6923
<http://www.alphawire.com>

THERMAL GREASE

AAVID Thermalloy Technologies, Inc

603-224-9988 Fax 603-223-1790
<http://www.aavidthermalloy.com>

VOLTAGE TRANSIENT SUPPRESSORS

MicroSemi Corp./Santa Ana Division

800-713-4113 Fax 949-756-0308
<http://www.microsemi.com>

Semtech Corp.

805-498-2111 Fax 805-498-3804
<http://www.semtech.com>

Vishay

610-407-4800 Fax 610-640-9081
<http://www.vishay.com>

NOTE:

Many of the above items can be purchased in small quantities through distributors such as:

Allied Electronics

800-433-5700
<http://www.alliedelec.com>

DigiKey Corporation

800-344-4539 Fax 218-681-3380
<http://www.digikey.com>

Mouser Electronics

800-346-6873 Fax 817-804-3899
<http://www.mouser.com>

Newark InOne

800-463-9275 Fax 773-907-5339
<http://www.newark.com>